



400 Series

404C-22G

Diesel Engine – Electropak

20.3 kWm 1500 rev/min
 23.9 kWm 1800 rev/min
 33.4 kWm 3000 rev/min

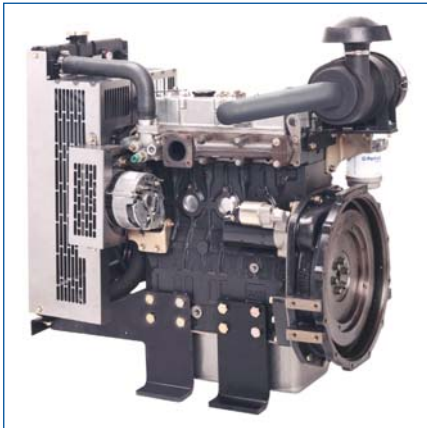

Compact, efficient power

A class-leading engine package coupled with an innovative, newly designed cooling pack provides optimum power density, making installation and transportation easier and cheaper. This package has been specially designed to hit the key power nodes required by the power generation industry.

Quiet, clean power

The 404C-22G has an exceptionally low noise signature making it the ideal choice for power generation in any environment. A high compression ratio also ensures clean rapid starting in all conditions. Design features ensure maximum cleanliness in terms of emissions throughout the engines operating life.

Reliable power

Developed and tested using the latest engineering techniques this engine reliably provides power when you need it. Operating and maintenance costs are reduced through excellent fuel and oil economy whilst whole-life costs are enhanced by a 500 hour service interval and a 2 year warranty. Excellent service access further improves maintenance and support is provided by a worldwide network of 4000 distributors and dealers.

The Perkins 400 Series provides compact power from a robust family of 2, 3 and 4 cylinder diesel engines, designed to meet today's uncompromising demands within the power generation industry.

The 404C-22G is a compact 4-cylinder naturally aspirated diesel engine. It's premium features provide economic and durable operation for standby duty, low gaseous emissions, overall performance and reliability.

Engine Speed (rev/min)	Type of Operation	Typical Generator Output (Net)		Engine Power			
		kVA	kWe	Gross		Net	
				kWm	bhp	kWm	bhp
1500	Prime Power	20.3	16.3	18.7	25.1	18.4	24.6
	Standby (maximum)	22.7	18.2	20.6	27.6	20.3	27.2
1800	Prime Power	23.4	18.7	22.0	29.5	21.6	28.9
	Standby (maximum)	25.3	20.2	24.3	32.6	23.9	32.1
3000	Prime Power	33.8	27.0	31.2	41.8	30.2	40.5
	Standby (maximum)	36.7	29.3	34.4	46.1	33.4	44.8

The above ratings represent the engine performance capabilities to conditions specified in ISO 8528/1, ISO 3046/1:1986, BS 5514/1.

Derating may be required for conditions outside these; consult Perkins Engines Company Limited.

Generator powers are typical and are based on typical alternator efficiencies and a power factor (cos θ) of 0.8.

Fuel specification: BS 2869: Part 2 1998 Class A2 or ASTM D975 D2.

Lubricating oil: To API CH4/ACEA E5.

Rating Definitions

Prime Power: Power available at variable load in lieu of a main power network. Overload of 10% is permitted for 1 hour in every 12 hours operation.

Standby (maximum): Power available at variable load in the event of a main power network failure. No overload is permitted.

400 Series

404C-22G

Standard ElectropaK Specification

Air inlet

- Mounted air filters

Fuel system

- Mechanically governed cassette type fuel injection pump
- Split element fuel filter

Lubrication system

- Wet steel sump with filler and dipstick
- Spin-on-full-flow lub oil filter

Cooling system

- Thermostatically-controlled system with belt driven circulating pump and pusher fan
- Mounted radiator and piping

Electrical equipment

- 12 volt starter motor and 12 volt 55 amp alternator with DC output
- Oil pressure and coolant temperature switches
- 12 volt shut off solenoid energised to run
- Glow plug cold start aid and heater/starter switch

Flywheel and housing

- 1500/1800 rev/min
 - High inertia flywheel to SAE J620 Size 7½ Heavy
 - Flywheel housing SAE 4 Long
- 3000/3600 rev/min
 - High inertia flywheel to SAE J620 Size 7½ Light
 - Flywheel housing SAE 4 Short

Mountings

- Front and rear mounting bracket

Literature

- User's Handbook

Optional Equipment

- Exhaust silencer
- Workshop manual
- Parts book

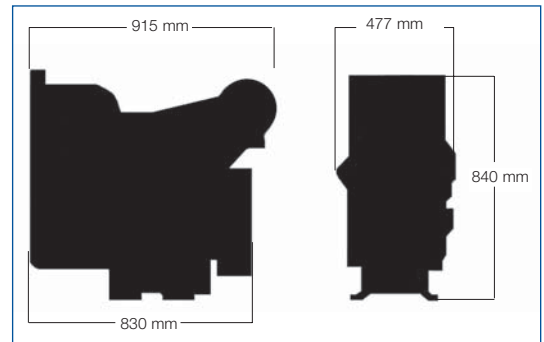

General Data

Number of cylinders	4
Cylinder arrangement	Vertical in-line
Cycle	4 stroke
Induction system	Natural aspiration
Combustion system	Indirect injection
Cooling system	Water-cooled
Bore and stroke	84 x 100 mm
Displacement	2216cc
Compression ratio	23.3:1
Direction of rotation	Anti-clockwise viewed on flywheel
Total lubrication system capacity	10.6 litres
Total coolant capacity	6.98 litres
Length	915 mm
Width	477 mm
Height	840 mm
Dry weight (engine)	242 kg (1500/1800 rev/min) 218 kg (3000 rev/min)

Final weight and dimensions will depend on completed specification.

Engine Speed	Fuel Consumption					
	1500 rev/min		1800 rev/min		3000 rev/min	
	g/kWh	l/hr	g/kWh	l/hr	g/kWh	l/hr
At Standby Rating	254	6.2	252	7.3	254	10.4
At Prime Power	243	5.4	245	6.4	256	9.5
At 75% Prime Power	243	4.0	247	4.8	269	7.5
At 50% Prime Power	265	2.9	269	3.5	313	5.8



Perkins Engines Company Limited

Peterborough PE1 5NA
United Kingdom
Telephone +44 (0)1733 583000
Fax +44 (0)1733 582240
www.perkins.com

Distributed by