

# 1100 Series

## 1104C-44TAG1

Diesel Engine - ElectropaK

78 kWm 1500 rev/min

89 kWm 1800 rev/min



### Compact and Efficient Power

The Perkins 1100 Series family was developed following an intensive period of customer research. The 3.3 and 4.4 litre engines feature new cylinder blocks which ensure bore roundness is maintained under the pressures of operation, as well as significantly reducing mechanical and combustion noise. A new cross-flow cylinder head design optimises combustion control, and combines with turbocharger and charge cooler technology to achieve the best combination of power delivery and low exhaust emissions.

### Cleaner and Quieter Power

The refined structure of the 1100C range leads to an exceptionally low noise signature. To meet environmental needs swirl conditioned air is delivered through the new cross-flow cylinder head, and burns cleanly with the high pressure fuel from an advanced technology rotary pump.

### Quality by Design

Class A manufacturing improvements ensure that product reliability meets the high standards demanded by customers. Product design is focused on maintaining Perkins' legendary reputation for durability.

### Cost effective Power

The compact packaging and low noise performance of the 1100C range bring clear benefits to the Genset packager. Low cost of operation is assured by lower fuel and oil consumption, 500 hour service intervals, and the two year warranty.

### Product Support

Total worldwide service is provided through a network of 4,000 distributors and dealers. TIPSS - The Integrated Parts and Support System enables customers to specify and order parts electronically as well as service engines with on-line guides and service tools.

Building upon Perkins proven reputation within the power generation industry, the newly introduced 1100 Series range of ElectropaK engines now fit even closer to the needs of their customers.

In the world of power generation, success is greeted for those providing more for even less. Therefore with this new 1104C-44TAG1 unit, Perkins has engineered for its customers even higher levels of reliability, yet lowered the cost of ownership. And with six cylinder capability from a four cylinder package performance increases, but crucially, bare engine noise is lower than ever before.

Rapid starting and pick-up are naturally built-in especially for cold operation, but where legislation or local markets demand an emissions capability, then the 1104C-44TAG1 satisfies EU 2007 Stage II mobile off-highway legislation; and also complies to TA Luft (1986) regulations.

1100 Series see the marriage of technology to customer need. A 4.4 litre unit very quietly setting a new standard in prime power supply and standby for the power generation industry.

*Certified against the requirements of EU 2007 (EU 97/68/EC Stage II) legislation for non-road mobile machinery, powered by constant speed engines.*

Engine speed rev/min	Operation Type	Typical Generator Output (Net)		Engine Power			
		kVA	kWe	Gross		Net	
				kW	bhp	kW	bhp
1500	Prime Power	80.0	64.0	75.0	100.5	71.0	95.0
	Standby (maximum)	88.0	70.5	82.0	110.0	78.0	104.5
1800	Prime Power	90.0	72.0	84.0	112.5	80.0	107.0
	Standby (maximum)	100.0	80.0	94.0	126.0	89.0	119.0

The above ratings represent the engine performance capabilities to conditions specified in ISO 8528/1, ISO 3046/1:1986, BS 5514/1.

Derating may be required for conditions outside these; consult Perkins Engines Company Limited.

Fuel specification: BS 2869 Class 2 or ASTM D975 D2. Lubricating oil: API CH4/ACEA E5.

Generator powers are typical and are based on typical alternator efficiencies and a power factor and a power factor (cos φ) of 0.8.

#### Rating Definitions

**Prime power** - Power available for variable load in lieu of a main power network. Overload of 10% permitted for 1 hour in every 12 hours operation.

**Standby (maximum)** - Power available at variable load in the event of a main power network failure. No overload is permitted.

# 1100 Series

## 1104C-44TAG1

### Standard ElectropaK Specification

#### Air inlet

- Mounted air filter

#### Fuel system

- Rotary type pump
- Ecoplus fuel filter

#### Lubrication system

- Wet steel sump with filler and dipstick
- Spin-on oil filter

#### Cooling system

- Thermostatically-controlled system with gear-driven circulation pump and belt-driven pusher fan
- Mounted radiator and piping incorporating air-to-air charge cooler

#### Electrical equipment

- 12 volt starter motor and 12 volt 65 amp alternator with DC output
- 12 volt shutdown solenoid energised to run
- Glow plug cold start aid

#### Flywheel and housing

- Flywheel to SAE J620 size 10/11<sup>1</sup>/<sub>2</sub>
- SAE 3 flywheel housing

#### Literature

- User's handbook

#### Optional equipment

- 24 Volt alternator
- 24 Volt starter motor
- Workshop manual
- Parts book

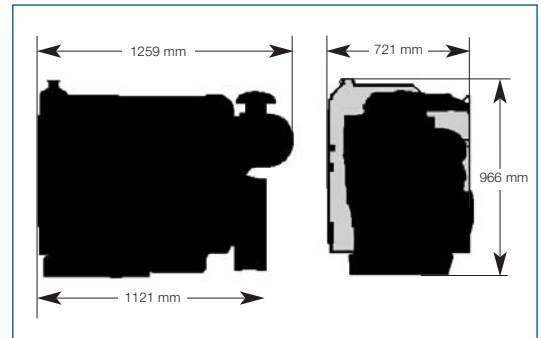

Engine Speed	Fuel Consumption			
	1500 rev/min		1800 rev/min	
	g/kWh	l/hr	g/kWh	l/hr
Standby	210	20.3	218	24.1
Prime power	211	18.6	223	22.0
75% of prime power	216	14.3	229	17.0
50% of prime power	222	9.8	237	11.7

#### General Data

Number of cylinders	4 vertical in-line
Bore and stroke	105 x 127 mm
Displacement	4.41 litres
Aspiration	Turbocharged, air to air charge cooled
Cycle	4 stroke
Combustion system	Direct injection
Compression ratio	18.2:1
Rotation	Anti-clockwise viewed on flywheel
Cooling system	Water-cooled
Total lubrication system capacity	8.0 litres
Total coolant capacity	12.6 litres
Dimensions	Length 1259 mm Width 721 mm Height 966 mm
Dry weight (ElectropaK)	500 kg

Final weight and dimensions will depend on completed specification.



#### Perkins Engines Company Limited

Peterborough PE1 5NA  
United Kingdom  
Telephone +44 (0)1733 583000  
Fax +44 (0)1733 582240  
[www.perkins.com](http://www.perkins.com)

All information in this document is substantially correct at time of printing and may be altered subsequently  
Publication No.1713/10/06 Produced in England ©2005 Perkins Engines Company Limited

Distributed by